

PAPER • OPEN ACCESS

Dual-frequency comb generation with differing GHz repetition rates by parallel Fabry–Perot cavity filtering of a single broadband frequency comb source

To cite this article: Jutta Mildner *et al* 2016 *Meas. Sci. Technol.* **27** 074011

View the [article online](#) for updates and enhancements.

You may also like

- [Optical analogue of the polaron: Dressed photon in a nonlinear Fabry–Pérot cavity](#)
Ze Cheng
- [Frequency noise measurement and its uncertainty estimation of an optical frequency comb using a delay line interferometer](#)
Masato Wada, Feng-Lei Hong and Hajime Inaba
- [Optical measurement of the gas number density in a Fabry–Perot cavity](#)
Isak Silander, Martin Zelan, Ove Axner *et al.*

Dual-frequency comb generation with differing GHz repetition rates by parallel Fabry–Perot cavity filtering of a single broadband frequency comb source

Jutta Mildner, Karl Meiners-Hagen and Florian Pollinger

Physikalisch-Technische Bundesanstalt (PTB), Bundesallee 100, 38116 Braunschweig, Germany

E-mail: florian.pollinger@ptb.de

Received 22 December 2015, revised 10 February 2016

Accepted for publication 17 February 2016

Published 31 May 2016



Abstract

We present a dual-comb-generator based on a coupled Fabry–Perot filtering cavity doublet and a single seed laser source. By filtering a commercial erbium-doped fiber-based optical frequency comb with CEO-stabilisation and 250 MHz repetition rate, two broadband coherent combs of different repetition rates in the GHz range are generated. The filtering doublet consists of two Fabry–Perot cavities with a tunable spacing and Pound–Drever–Hall stabilisation scheme. As a prerequisite for the development of such a filtering unit, we present a method to determine the actual free spectral range and transmission bandwidth of a Fabry–Perot cavity *in situ*. The transmitted beat signal of two diode lasers is measured as a function of their tunable frequency difference. Finally, the filtering performance and resulting beat signals of the heterodyned combs are discussed as well as the optimisation measures of the whole system.

Keywords: femtosecond frequency comb, cavity mode filtering, free spectral range measurement, length metrology, multi-wavelength interferometry

(Some figures may appear in colour only in the online journal)

1. Introduction

Femtosecond frequency combs are highly promising tools for many applications due to their advantageous spectral properties, such as large bandwidths, well-defined, stable repetitions rates and directly traceable discrete modes [1]. Applications comprise frequency synthesis and metrology [1], laser spectroscopy of gases [2, 3] and calibration of astronomical spectrographs [4, 5]. Spectral width, robustness and direct traceability to the SI definition of the metre make them excellent candidates as sources in optical length metrology [6]. Their application in multi-wavelength interferometry for (absolute) distance metrology appears particularly

conceptually appealing [7]. In this approach the frequency spectrum of the interference signal is analysed regarding its phase information. A heterodyne implementation of multi-wavelength interferometry was first proposed by Lay and co-workers [8]. For phase demodulation two frequency combs of different repetition rates are required. This (multi) heterodyne cross correlation measurement technique, often referred to as ‘dual-comb’ or modulation sideband technology for absolute ranging (MSTAR) interferometry, features advantages like high measurement rates and precision, easily accessible signal processing and an extendable non-ambiguity range [9–11]. However, acquisition and maintenance costs for two femtosecond lasers seem currently too high for broader application, e.g. in industrial metrology. We recently demonstrated dual-comb interferometry using a more cost-efficient electro-optic comb source [12]. The achievable uncertainty of this type of measurement depends critically on the bandwidth of



Original content from this work may be used under the terms of the [Creative Commons Attribution 3.0 licence](https://creativecommons.org/licenses/by/3.0/). Any further distribution of this work must maintain attribution to the author(s) and the title of the work, journal citation and DOI.

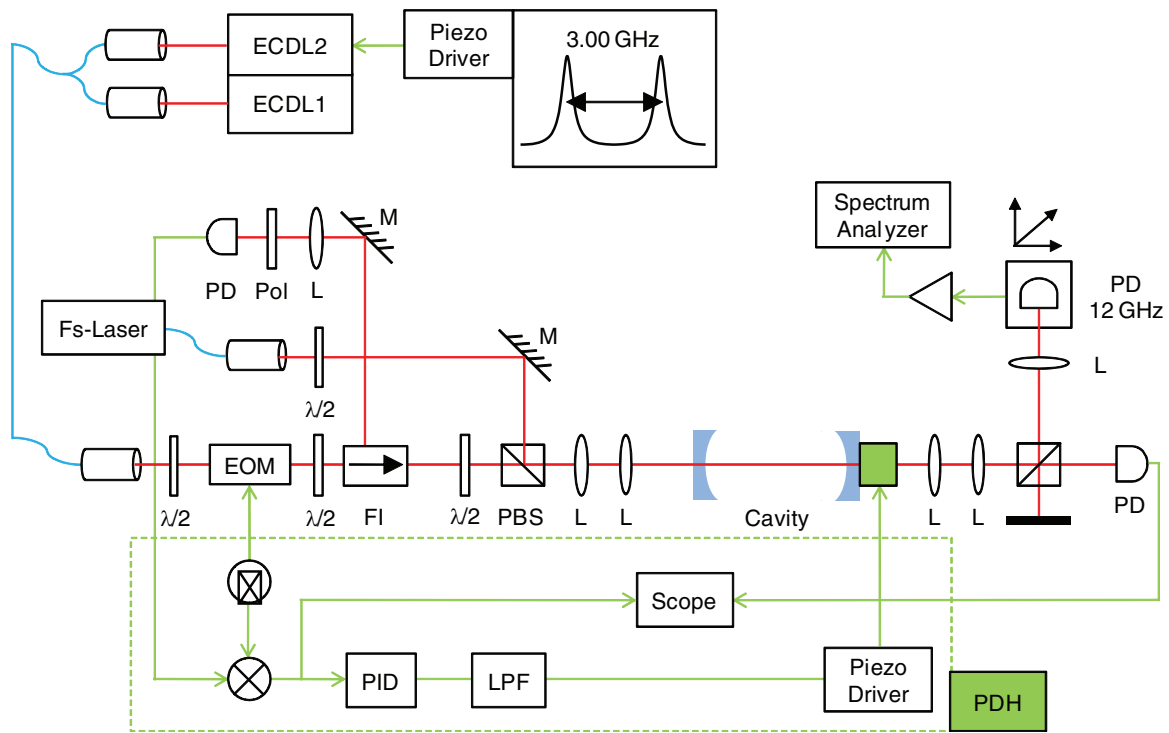

Figure 1. Experimental setup for cavity filtering with Pound–Drever–Hall stabilisation (PDH). ECDL: external cavity diode laser, EOM: electro-optic modulator, FI: Faraday isolator, L: lens, LPF: low pass filter, M: mirror, PBS: polarising beam splitter, PD: photodiode, PID: servo amplifier, Pol: thin film polariser. The green, red and blue lines indicate the electronic wiring scheme, laser beam path and optical fibres, respectively. ECDL1 is used for PDH stabilisation, while ECDL2 is optional and only used for $\Delta\nu_{\text{FSR}}$ characterisation.

the comb source [13]. Therefore, the use of octave-spanning fiber comb sources appears desirable for high-accuracy applications. In order to access individual comb modes, a prerequisite for classical interferometric analysis in multi-wavelength interferometry, the mode spacing should not be too small. Commercially available fiber-doped frequency combs, however, have relatively low repetition rates in the order of a few hundred MHz. Consequently, individual comb modes are difficult to separate with classical spectroscopic methods within reasonable dimensions. It should be noted that the low repetition rate and corresponding high mode density also prevents a direct application of frequency combs for the calibration of astronomical spectrographs. State-of-the-art spectrographs in this field, for example, feature a resolution of around 15 GHz [4].

As one approach to overcome this issue, frequency comb modes can be thinned out by a Fabry–Perot filtering cavity, being equivalent to multiplying the repetition rate. For this purpose the cavity’s free spectral range ($\Delta\nu_{\text{FSR}}$), i.e. its length, has to match a multiple of the laser’s repetition rate. This method was first proposed for generating an astronomical frequency comb in 2007 [5, 14] and has since been implemented in other experimental setups as well (see, e.g. [15, 16] and the references therein). A disadvantage of this approach, however, is the inevitable loss of power. In principle, this limits application, but can be overcome by using optical laser amplifiers following the cavity [17]. Nevertheless, there are several non-trivial challenges in setting up a Fabry–Perot cavity under controlled conditions for this purpose. Optical coupling requires both careful adjustment and matching of the laser

beam to the fundamental mode of the cavity. Furthermore, a stabilisation scheme is mandatory for a robust transmission and has to be implemented. Above all, the cavity length has to be positioned with sub-micrometer accuracy in advance to satisfy the filtering criterion. Otherwise, no comb mode is transmitted and no optimisation measure, e.g. mode-matching, can be performed.

Several methods to determine $\Delta\nu_{\text{FSR}}$ for this purpose have been reported. For once, it can be directly measured by observing the transmission spectrum while tuning the incident laser wavelength [18, 19, 20]. The precision of such an approach is typically limited to $4 \cdot 10^{-6}$ by the resolution of the optical spectrum analyser [20]. Most techniques utilise phase-modulation of the laser with a modulation frequency around $\Delta\nu_{\text{FSR}}$, while measuring the reflected and/or transmitted power from the cavity. Due to the targeted flat response of the power signal, the method is often referred to as the ‘null method’ (see, e.g. [21] and the references therein). A similar technique deploys a modified Pound–Drever–Hall (PDH) scheme, in which the derived error signal is analysed while additionally scanning the modulation frequency [22, 23]. Both methods are only limited by the laser linewidth and cavity finesse reaching a precision of up to 10^{-8} [21, 23]. Precise control of $\Delta\nu_{\text{FSR}}$ has been demonstrated by the use of two detuned probe laser beams [24, 25].

In this paper, we demonstrate cavity-filtering as a possibility to generate a comb doublet for length metrology using a single frequency comb source. For the implementation, we present an alternative approach for the determination of $\Delta\nu_{\text{FSR}}$, which significantly simplifies the tedious alignment

of respective filters in practice. The technique is then applied to develop a pair of Fabry–Perot cavities with different, preset free spectral ranges. By seeding the coupled filtering doublet with one femtosecond frequency comb source, two coherent combs of different, multiplied repetition rates are generated. This ‘dual-comb-generator’ represents the basis for a novel concept of and a cost-saving solution for multi-wavelength interferometry based on optical frequency combs to push relative measurement uncertainties in long distance metrology into the regime of better than 10^{-7} . The applicability of the dual combs to MSTAR-related schemes is demonstrated by beat note experiments at the end of this paper.

2. Experimental setup

The experimental setup for frequency comb mode filtering, PDH stabilisation and $\Delta\nu_{\text{FSR}}$ determination is shown in figure 1 for a single Fabry–Perot filter cavity. The optical frequency synthesiser to be filtered is based on a mode-locked erbium-doped fiber laser (Menlo Systems FC1500), whose output is amplified and frequency-doubled to provide laser pulses of $\tau_p = 62$ fs pulse duration centered at $\lambda = 790$ nm with a repetition rate of $f_{\text{rep}} = 250$ MHz and a mean power of $P > 150$ mW. The frequency of the comb line is offset-stabilised with a carrier-envelope offset frequency of $f_{\text{CEO}} = 20$ MHz (40 MHz for the frequency-doubled beam). Furthermore, two external cavity diode lasers are used for cavity stabilisation and characterisation, respectively. Both diode lasers are combined by a fused fibre coupler with parallel polarisation. The frequency of ECDL2 (Sacher Lasertechnik) can be tuned by a piezo driver to adjust the frequency difference between both diode lasers, the resulting tunable beat signal being used for $\Delta\nu_{\text{FSR}}$ determination.

The Fabry–Perot filtering cavity consists of two UV-fused silica plano-concave mirrors with -100 mm radius of curvature and high-reflection coating of $R = 98\%$ (Laseroptik). The group velocity dispersion (GVD) of the mirror coatings is less than 10 fs $^{-2}$ around 780 nm to avoid a wavelength-dependent $\Delta\nu_{\text{FSR}}$. The rear mirror is attached to a ring piezo-actuator with matched casing and a total motion range of 12 μm (Piezosystem Jena RA12/24). Furthermore, the cavity is enclosed by two mode-matching lenses on each side with focal lengths of $+50$ mm and -20 mm in front of the cavity as well as -50 mm and $+60$ mm after the cavity for proper beam collimation.

The cavity is stabilised by a Pound–Drever–Hall (PDH) scheme [26]. An electro-optic modulator (EOM) is used to generate sidebands on ECDL1 (Toptica DL pro). The modulated light passes a Faraday isolator (FI) before being reflected at the entrance mirror of the cavity. The reflected light is filtered out by the FI, containing beat signals between the carrier frequency and modulation sidebands, and is detected by a 200 MHz photoreceiver (Femto HCA-S-200M-SI). The diode signal is then mixed with the EOM driving signal. The resulting error signal is used for feedback control by a servo amplifier (PID-controller) and monitored on an oscilloscope in parallel. The feedback signal is low pass filtered and fed to

the piezo driver of the ring piezo attached to the rear mirror, closing the feedback loop to stabilise the cavity length for maximum transmission.

Frequency comb and diode laser radiation are superposed by a polarising beam splitter cube (PBS) before passing the Fabry–Perot cavity. The transmitted light is then split by a non-polarising beam splitter cube and detected by two different photodiodes. A large-area silicon photoreceiver (New Focus 2031) is used to monitor the continuous wave (cw) ECDL transmission. To detect beat signals in the radio frequency (RF) regime the laser beam is focused onto a 12 GHz amplified free-space photoreceiver (New Focus 1577-A) fixed on a three-dimensional translation stage. The RF signal is then again amplified and analysed by an RF-spectrum analyser (Rohde & Schwarz FSV30). The optical spectra are characterised by a commercial optical spectrum analyser (Yokogawa AQ6373B).

3. Cavity adjustment and characterisation

The Fabry–Perot filtering cavities are set up in a configuration lying in-between a confocal and near-planar one, as the mirror radius of curvature r is larger than the mirror separation, i.e. cavity length l , but not as much as $r \gg l$. The confinement condition for optical resonators [27],

$$0 \leq \left(1 - \frac{l}{|r|}\right)^2 \leq 1, \quad (1)$$

gives a value of 0.25 for, e.g. $l = 49.97$ mm, and the given radius of curvature $r = -100$ mm, where 0 represents the symmetric confocal case and 1 the plane-parallel one. Both configurations lie on the verge of non-confinement, meaning a strong sensitivity to small changes in the parameters. Thus, it is of clear advantage to stay within the (low-loss) area in-between.

For these parameters a free spectral range $\Delta\nu_{\text{FSR}}$ of 3.00 GHz is achieved according to

$$\Delta\nu_{\text{FSR}} = \frac{c}{2nl} \quad (2)$$

with c being the speed of light in vacuum and n the index of refraction. The transmitted power, determined by the mirror reflectivity $R = 98\%$ and losses of $\leq 0.25\%$, should be 76.6% in theory. The cavity finesse \mathcal{F} is defined as the ratio between $\Delta\nu_{\text{FSR}}$ and transmission bandwidth $\delta\nu$, and can be related to the reflectivity R of the (near-planar) mirrors by [28]

$$\mathcal{F} = \frac{\Delta\nu_{\text{FSR}}}{\delta\nu} = \frac{\pi\sqrt{R}}{1-R}. \quad (3)$$

Equation (3) then gives (upper limits of) $\mathcal{F} = 155.5$ and $\delta\nu = 19.29$ MHz for the applied parameters.

To adjust the cavity mirrors and length coarsely, the ring piezo attached to the rear mirror is scanned with a standard triangle signal at 28.5 Hz, while the diode laser transmission of ECDL1 and the generated error signals are monitored. When both signals are optimised, as illustrated in figure 2(a) for a slow

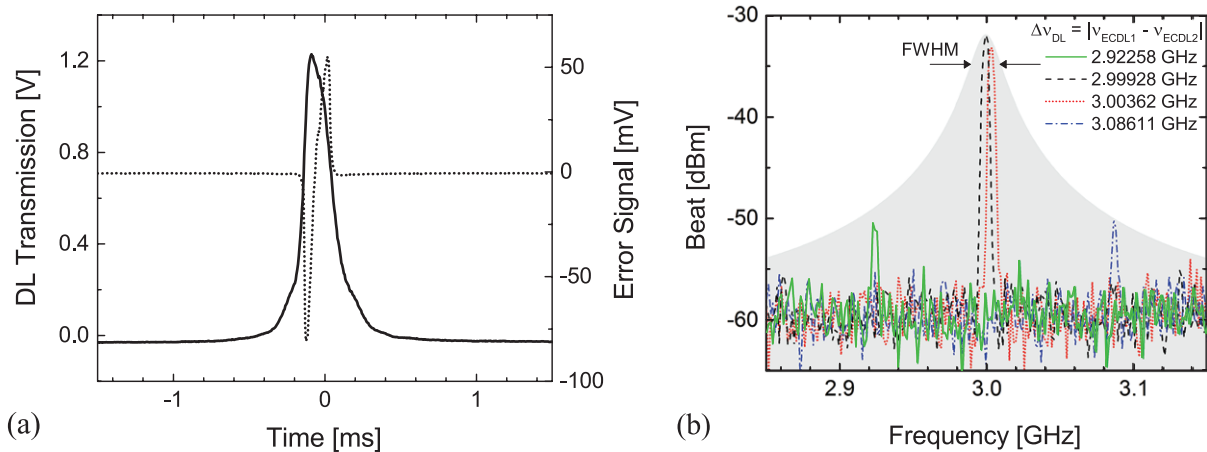

Figure 2. (a) ECDL1 transmission (solid line) and the corresponding PDH error signal (dotted line) for a slow modulation frequency of 10 MHz, while scanning the cavity length at 28.5 Hz. (b) Mapping of the cavity transmission envelope (grey shaded area) by scanning the frequency difference $\Delta\nu_{DL}$ between both ECDLs. The four displayed traces correspond to four detuned ECDL configurations. The transmission bandwidth of $\delta\nu = 20.26$ MHz at FWHM is indicated with arrows. The small beat signals at the edges of the transmission envelope are separated by 163.53 MHz.

modulation frequency of 10 MHz, the PDH stabilisation can be activated. The locking point is set to the zero crossing of the error signal, which corresponds to a maximum diode laser transmission. The PDH stabilisation is then stable during the whole day with fluctuations typically in the range of $\pm 2.5\%$ (30 mV) in DL transmission and $\pm 8\%$ (10 mV) in error signal. The typical long-term frequency change of ECDL1 with room temperature is specified to be $\ll 100$ MHz K^{-1} . Under laboratory conditions, the frequency is therefore stable in the order of 10^{-7} . It should be noted that due to the filtering principle, the stability of the comb modes of the filtered combs is determined by the seeding frequency comb. Drifts of ECDL1 only lead to slowly varying amplitude modulations of the cavity transmission. As the cavity is strongly sensitive to any kind of vibration, e.g. due to air flow and electronic equipment, the fluctuations can rise to $\pm 6\%$ (70 mV) and $\pm 20\%$ (25 mV), respectively, while the femtosecond laser system is running. The mean transmission efficiency is then about 65.1% and not far from the theoretical value of 76.6%.

For fine adjustment and to determine $\Delta\nu_{FSR}$ and transmission bandwidth, the second ECDL is used. By tuning the frequency of ECDL2 by a piezo driver the frequency difference $\Delta\nu_{DL} = |\nu_{ECDL1} - \nu_{ECDL2}|$ between both diode lasers can be adjusted to a beat frequency lying within the transmission bandwidth of the Fabry–Perot filtering cavity. Four such detuned ECDL configurations around the cavity's $\Delta\nu_{FSR}$ of 3.00 GHz are displayed in figure 2(b) exemplarily. When the desired $\Delta\nu_{FSR}$ of the cavity is not achieved yet, the actual cavity length can be determined in this way and adjusted iteratively. The actual $\Delta\nu_{FSR}$ corresponds to the position of the maximum beat signal when the cavity length is locked. The precision of this approach is given by the laser linewidth and resolution of the spectrum analyser in use. The typical linewidth of ECDL1 is specified to be ~ 200 kHz (5 μ s integration time). The frequency readout resolution of the spectrum analyser is 0.1 Hz, while the marker resolution is 1 Hz. For the given span of 1 GHz on the spectrum analyser (see figure 2(b)) $\Delta\nu_{FSR}$ was determined to 2.9993 GHz with an accuracy of ± 1.5 MHz, leading to a precision of $5 \cdot 10^{-4}$.

For a cavity bandwidth of ~ 20 MHz a corresponding smaller span can be used to achieve a precision of $< 7 \cdot 10^{-5}$ limited by the given laser linewidth.

In the same way the envelope of the cavity transmission can be mapped as well. While scanning the frequency difference between both diode lasers manually, shifting of the transmitted beat signal (see snapshots in figure 2(b)) is observed. As the mean power of ECDL2 is sufficiently lower compared to the stabilising ECDL1 (less than 10%) ECDL2 can be scanned or detuned, although both laser beams are modulated with the same EOM. The full width at half maximum (FWHM) transmission bandwidth is thus determined to 20.26 MHz, which is in good agreement with the theoretical value for $\delta\nu$ of 19.29 MHz. The two small beat signals in figure 2(b) separated by 163.53 MHz lie at the edges of the cavity's transmission envelope (indicated by the grey shaded area) according to the corresponding detuned ECDL configurations. The peak positions are given by the deviation of the DL's frequency difference from the cavity's free spectral range $\Delta\nu_{FSR} \pm \Delta\nu_{DL}$, resulting in a signal level of around 1.5% compared to the maximal transmission (note that the left-hand axis in figure 2(b) has a logarithmic scale). Please note that this result is a convolution of the laser linewidth with the cavity transmission bandwidth, leading to a larger value compared to the true bandwidth [29].

4. Dual-comb-generation

The spectrum of an optical frequency comb ν_{comb} , as generated, e.g. by the optical fibre comb mentioned before, can be described by

$$\nu_{comb} = f_{CEO} + \sum_{i=n_1}^{n_{final}} i \cdot f_{rep}, \quad (4)$$

with $n_1, n_{final} \in \mathbb{N}$ denoting the bandwidth of the spectrum, f_{CEO} the carrier envelope offset frequency, and f_{rep} the repetition rate [1]. If the free spectral range $\Delta\nu_{FSR}$ of the cavity described above is matched to a multiple of the repetition rate, i.e.

$$\Delta\nu_{\text{FSR}} \stackrel{!}{=} m \cdot f_{\text{rep}}, \quad (5)$$

the cavity acts as a filter to generate a frequency comb with the higher repetition rate $\Delta\nu_{\text{FSR}}$, while maintaining to first order the bandwidth of the seed comb. This effect is known as repetition rate multiplication [16]. It should be noted that in theory, such a match of free spectral range and comb modes would require f_{CEO} to vanish. In practice, however, there was no change in filtering performance visible when the offset frequency of 40 MHz (frequency doubled) was compensated for by shifting the laser frequency by 210 MHz in sum with two acousto-optic modulators (AOMs), neither in the quality of the filtered RF spectra, nor in the transmission efficiencies. Actually a rough calculation can explain that: assuming that the cavity length is chosen to match a comb line in the centre spectrum (order $m_c \approx 10^6$) perfectly, the neighbouring modes ($m_c + 15$) and ($m_c - 15$) are only detuned by f_{CEO}/m_c . This mismatch would amount to less than 40 Hz for the next mode for the given experimental parameters. Thus, compared to a cavity transmission bandwidth $\delta\nu$ of ~ 20 MHz this is negligible: $2 \cdot 10^{-6}$. Although the mismatch increases with each mode towards the edges of the laser spectrum, it would be < 13 kHz at most, corresponding to $< 0.065\%$ in relation to the given bandwidth. We therefore omitted a CEO adjustment in our experiment.

In this study, the basic filter design was used to realise a dual-comb-generator for a coherent comb pair. The Fabry–Perot filtering cavity was duplicated with minor modifications for this purpose. The length adjustment of the two cavities, i.e. tuning their free spectral ranges $\Delta\nu_{\text{FSR}}$, was done according to the procedure as described in section 3. The PDH control of both cavities is performed using only one diode laser (ECDL1). Its beam is distributed on the two cavities by a fibre splitter. Each split beam is then modulated with two different modulation frequencies separately (10 MHz in front of cavity 1 and 61 MHz in front of cavity 2). The returning error signals are therefore different (i.e. slow and fast modulation, respectively) and detected completely separated as well. Both feedback control systems are electronically independent from each other.

The frequency comb source is the same femtosecond laser as described in section 2 and split by a separate fibre coupler to serve both Fabry–Perot filtering units simultaneously as well. As ECDL1 stabilises both cavities and the frequency comb is filtered by the very cavities, the two lasers should be frequency stabilised onto each other, e.g. by a phase-locked loop (PLL). However, in practice, it turned out to be no problem for our dual-comb-generator, because the cavity bandwidths are quite large. Drifts of ECDL1 only lead to slowly varying amplitude modulations of the cavity transmission. The frequency stability of the filtered comb modes remains unaffected, as the corresponding stability of the seeding frequency comb source is preserved. Furthermore, for the application in multi-wavelength interferometry for long-distance metrology the benefit in measurement uncertainty will not be significant. Therefore, we omitted the additional PLL stabilisation to not extend the experimental setup unnecessarily.

The target of this study was the generation of a comb pair with a difference in mode spacing of $\Delta m = m_2 - m_1 = 1$, corresponding to a difference in repetition rate of 250 MHz. This was exemplarily realised by a cavity doublet of free spectral ranges $\Delta\nu_{\text{FSR},1} = 3.50$ GHz and $\Delta\nu_{\text{FSR},2} = 3.75$ GHz, corresponding to filtering ratios of $m_1 = 14$ and $m_2 = 15$ and cavity lengths of $l_1 = 42.83$ mm and $l_2 = 39.97$ mm, respectively.

Figure 3 shows the simplified principle of our dual-comb-generator. The displayed graphs are comb mode spectra in the form of intermode beat signals measured by the fast (12 GHz) photoreceiver and RF-spectrum analyser. This so-called optical beat comb arises from intermode beats of all mode pairs in an optical frequency comb ranging from its repetition rate value in the RF regime up to THz frequencies due to the large spectral bandwidth of the laser [10].

A part of the unfiltered frequency comb mode spectrum of the seed laser source is given on the left-hand side in figure 3. The dual-comb-generator is indicated in form of the Fabry–Perot cavity doublet in the centre, and the filtered frequency comb mode spectra are displayed on the right. The first transmitted mode from cavity 1 occurs at 3.50 GHz, the second at 7.00 GHz etc, and from cavity 2 at 3.75 GHz, 7.50 GHz etc, i.e. multiples of $\Delta\nu_{\text{FSR}}$, with decreasing signal strength. Some comb modes are not efficiently suppressed or filtered out, e.g. around 3.50 GHz after cavity 1 and at 2.25 GHz after cavity 2. Their signal levels are 10 to 19 dB smaller than the corresponding first transmitted mode. This difference corresponds to a mode suppression ratio of 10 : 1 up to 79 : 1. This unwanted transmission can originate from the relatively low finesse (i.e. mirror reflectivity) and/or suboptimal coupling of the laser beam to the cavity. The latter is strongly dependent on adjustment and mode-matching optics. The same dependence applies to the transmission efficiency. In the case of cavity 1 the DL power transmission efficiency is 84.5%, while for cavity 2 53.2% is achieved. Regarding the frequency comb a mean power of only 0.73% and 0.98% is measured after filtering by cavity 1 and 2, respectively, the main power being stored within the cavities, i.e. between the high reflecting mirrors. It should be noted that the DL transmission efficiency only serves as a measure for optical coupling to the cavity and is limited by the losses at the cavity mirrors, determined by their anti-reflection coating. Concerning the comparatively small value for the frequency comb, the large power loss is comprehensible due to the applied filtering ratios of 14 and 15, ideally transmitting no more than $\sim 7\%$ of the original comb modes. On top of that there will be additional losses due to the transmission bandwidth $\delta\nu$ or cavity finesse, respectively, as well as real optical coupling as mentioned above.

For application in multi-wavelength interferometry, i.e. generation of synthetic wavelengths, the (optical) centre frequencies ν_c of both filtered combs have to be different. To that end acousto-optic modulators driven at $f_{\text{AOM},1} = 100$ MHz and $f_{\text{AOM},2} = 110$ MHz are used to shift the centre frequencies of the generated combs by different values, resulting in a total centre frequency difference

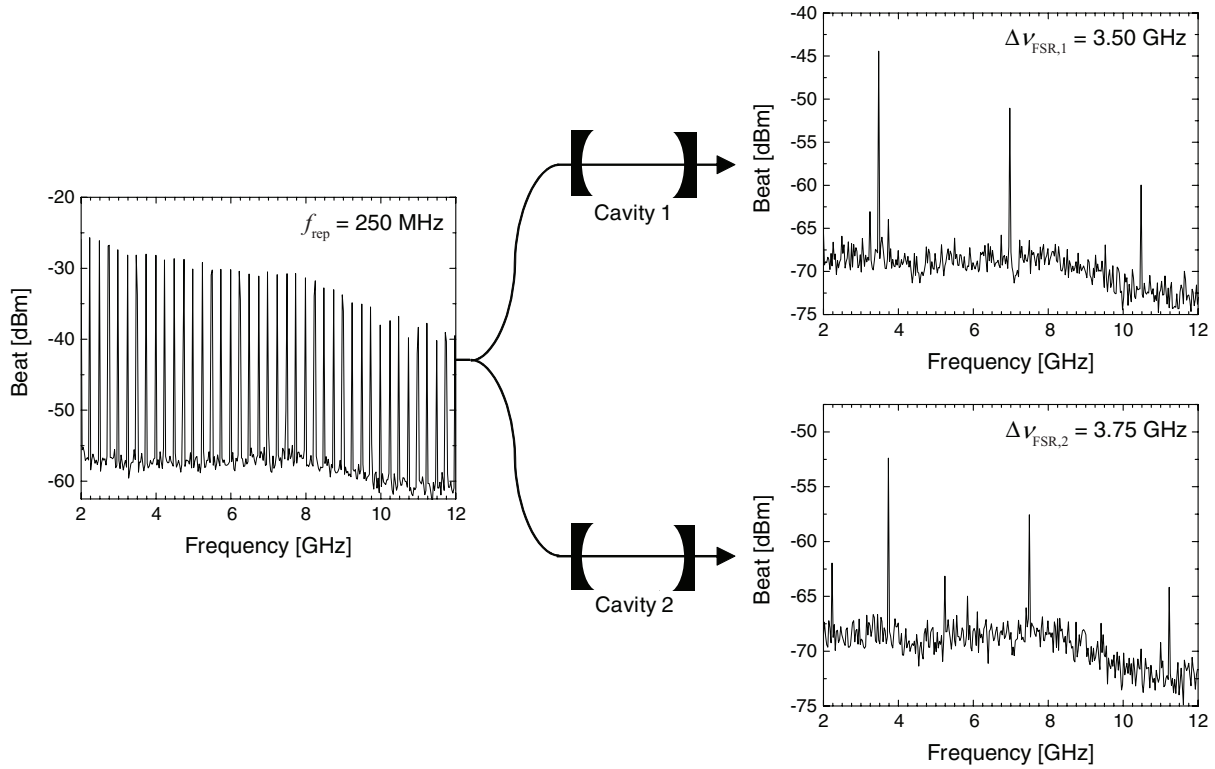

Figure 3. Dual-comb-generator, from left to right: mode spectrum of the seed frequency comb with a repetition rate of 250 MHz. After splitting and filtering by a coupled Fabry–Perot cavity doublet two wide spaced combs with slightly different repetition rates of 3.50 GHz and 3.75 GHz are generated. Unwanted comb modes are suppressed by ~ 19 dB for cavity 1 and ~ 10 dB for cavity 2.

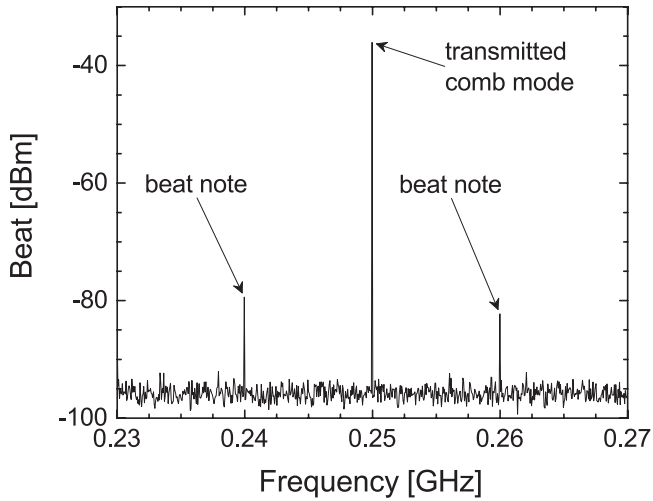

Figure 4. Beat signals at 240 MHz and 260 MHz between the two generated wide spaced combs of different repetition rates (3.50 GHz and 3.75 GHz) and centre frequencies ($\Delta\nu_c = 10$ MHz). The signal at 250 MHz originates from not sufficiently suppressed modes of the seed laser, its signal level being higher due to the sensitivity of the 1 GHz photoreceiver used.

$$\begin{aligned} \Delta\nu_c &= |\nu_{c,1} - \nu_{c,2}| \\ &= |(\nu_c + f_{\text{AOM},1}) - (\nu_c + f_{\text{AOM},2})| \end{aligned} \quad (6)$$

of 10 MHz, where the centre frequencies of the filtered combs are initially the same. Synthetic wavelength generation is then realised by combining both wide spaced combs again with a fused fibre coupler. The resulting beat signals are detected by a 1 GHz photoreceiver (Femto HSA-X-S-1G4-SI-FS) and

displayed in figure 4. The graph indicates only a small part of the generated synthetic wavelength chain, consisting of

$$\Lambda_{(k_1, k_2)} = \frac{c}{|f_{\text{rep}}(k_1 m_2 - k_2 m_1) - \Delta\nu_c|} \quad (7)$$

$$= \frac{c}{f_{\text{beat},(k_1, k_2)}} \quad (8)$$

where $k_{1,2} \in \mathbb{Z}$ is a running index of the unfiltered comb modes. According to equation (7) the peaks at 240 MHz and 260 MHz in figure 4 can be assigned to the beat signals/frequencies $f_{\text{beat},(1,1)}$ and $f_{\text{beat},(-1,-1)}$, respectively. The peak at 250 MHz can be related to an intermode beat of not sufficiently suppressed frequency comb modes. Its large signal level compared to figure 3 is due to the more sensitive 1 GHz photoreceiver in use. Due to fibre coupling losses and removing the diode laser by polarisation optics less than 100 μW are left from several mW of optical power provided by the dual-comb-generator.

As mentioned in section 1 the achievable uncertainty in dual-comb interferometry depends critically on the bandwidth of the combs. To check on the bandwidth, the optical spectra of the seed laser source before and after cavity filtering are measured. Figure 5 illustrates an exemplary comparison between the seed laser (upper spectrum) and the filtered comb after cavity 1 (lower spectrum). The spectral FWHM of the frequency comb of 5 nm, corresponding to 2.4 THz, is clearly preserved showing the advantage of the presented dual-comb-generator.

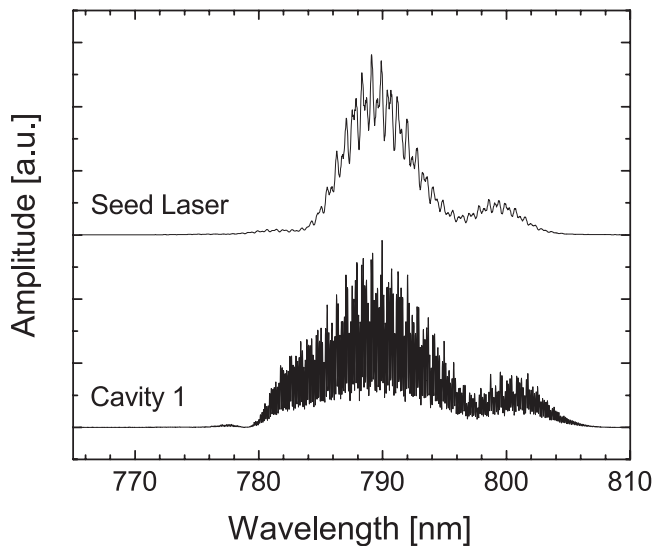

Figure 5. Optical spectrum of the seed laser source (upper spectrum) and filtered spectrum after cavity 1 (lower spectrum). Both spectra are normalised and separated by an offset for comparison, illustrating the preservation of the spectral width during mode filtering (5 nm corresponding to 2.4 THz at FWHM).

5. Summary

In summary, we presented the development of a tunable Fabry–Perot filtering cavity doublet for the generation of coherent dual-frequency combs with GHz repetition rates from a single fibre-based femtosecond frequency comb source.

We determined $\Delta\nu_{\text{FSR}}$ of the cavities with a precision in the range of $5 \cdot 10^{-4}$ down to $<7 \cdot 10^{-5}$ by measuring the transmitted beat signal between two ECDLs, whose frequencies are detuned in the range of the actual $\Delta\nu_{\text{FSR}}$. This method represents a new and straightforward way for free spectral range characterisation and adjustment. A PDH scheme was deployed for stabilisation of the cavity lengths on the desired $\Delta\nu_{\text{FSR}}$. With high-reflectivity mirrors of $R = 98\%$ separated by 42.83 mm and 39.97 mm, two filtering cavities were realised with $\Delta\nu_{\text{FSR}}$ of 3.50 GHz and 3.75 GHz, respectively. They feature a power transmission efficiency between 53.2 and 84.5% and a calculated finesse \mathcal{F} of 155.5. The transmission bandwidth $\delta\nu$ was determined in the same way as $\Delta\nu_{\text{FSR}}$ to 20.26 MHz at FWHM. The filtering performance or repetition rate multiplication, respectively, was demonstrated with a filtering ratio of 14 and 15 regarding the laser's repetition rate of 250 MHz, seeding both cavities simultaneously. A mode suppression ratio of at least 10 : 1, corresponding to 10 dB, was achieved while preserving the optical bandwidth of the seed laser. For stronger mode suppression and higher repetition rate multiplication, the cavity finesse has to be increased and the cavity length reduced, respectively. In this case one has to be aware that mode-matching and stabilisation become more critical and the transmitted power will be decreased.

The so-generated dual-frequency comb was applied to a preliminary beat note experiment, in which both optical centre frequencies were shifted by AOMs to result in a centre frequency difference of 10 MHz and therefore in beat signals

of, e.g. (250 ± 10) MHz when the two filtered combs are heterodyned. Individual comb lines can then be isolated along the lines of the MSTAR principle. The full bandwidth can be used after pre-selection of specific spectral regions of interest. Thus, the dual-comb-generator presented here is a significant milestone towards a full implementation of the MSTAR principle for length metrology with femtosecond frequency combs featuring relative measurement uncertainties below 10^{-7} and direct traceability to the SI definition of the metre.

Acknowledgments

The authors would like to thank Jennifer Bautsch for her technical assistance and Steven van den Berg for his fruitful discussions. This project is performed within the joint research project SIB60 ‘Surveying’ of the European Metrology Research Programme (EMRP). The EMRP is jointly funded by the EMRP participating countries within EURAMET and the European Union.

References

- [1] Udem T, Holzwarth R and Hänsch T W 2002 Optical frequency metrology *Nature* **416** 233–7
- [2] Gohle C, Stein B, Schliesser A, Udem T and Hänsch T W 2007 Frequency comb vernier spectroscopy for broadband, high-resolution, high-sensitivity absorption and dispersion spectra *Phys. Rev. Lett.* **99** 263902
- [3] Thorpe M J and Ye J 2008 Cavity-enhanced direct frequency comb spectroscopy *Appl. Phys. B* **91** 397–414
- [4] Murphy M T et al 2007 High-precision wavelength calibration of astronomical spectrographs with laser frequency combs *Mon. Not. R. Astron. Soc.* **380** 839–47
- [5] Schmidt P O, Kimeswenger S and Käuffel H U 2008 A new generation of spectrometer calibration techniques based on optical frequency combs *Proc. the 2007 ESO Instrument Calibration Workshop* (ESO Astrophysics Symp. Series) (Garching: Springer) p 409
- [6] Kim S-W 2009 Combs rule *Nat. Photon.* **3** 313–4
- [7] van den Berg S A, Persijn S T, Kok G J P, Zeitouny M and Bhattacharaya N 2012 Many-wavelength interferometry with thousands of lasers for absolute distance measurement *Phys. Rev. Lett.* **108** 183901
- [8] Lay O P, Dubovitsky S, Peters R D, Burger J P, Ahn S-W, Steier W H, Fetterman H R and Chang Y 2003 MSTAR: a submicrometer, absolute metrology system *Opt. Lett.* **28** 890–2
- [9] Coddington I, Swann W C, Nenadovic L and Newbury N R 2009 Rapid and precise absolute distance measurements at long range *Nat. Photon.* **3** 351–6
- [10] Yokoyama S, Yokoyama T, Hagihara Y, Araki T and Yasui T 2009 A distance meter using a terahertz intermode beat in an optical frequency comb *Opt. Express* **17** 17324–37
- [11] Lee J, Han S, Lee K, Bae E, Kim S, Lee S, Kim S-W and Kim Y-J 2013 Absolute distance measurement by dual-comb interferometry with adjustable synthetic wavelength *Meas. Sci. Technol.* **24** 045201
- [12] Yang R, Pollinger F, Meiners-Hagen K, Tan J and Bosse H 2014 Heterodyne multi-wavelength absolute interferometry based on a cavity-enhanced electro-optic frequency comb pair *Opt. Lett.* **39** 5834–7
- [13] Yang R, Pollinger F, Meiners-Hagen K, Krystek M, Tan J and Bosse H 2015 Absolute distance measurement by

- dual-comb interferometry with multi-channel digital lock-in phase detection *Meas. Sci. Technol.* **26** 084001
- [14] Osterman S, Diddams S, Beasley M, Froning C, Hollberg L, MacQueen P, Mbele V and Weiner A 2007 A proposed laser frequency comb-based wavelength reference for high-resolution spectroscopy *Proc. SPIE* **6693** 66931G
- [15] Steinmetz T, Wilken T, Araujo-Hauck C, Holzwarth R, Hänsch T W and Udem T 2009 Fabry–Perot filter cavities for wide-spaced frequency combs with large spectral bandwidth *Appl. Phys. B* **96** 251–6
- [16] Lešundák A, Šmíd R, Voigt D, Čížek M, van den Berg S A and Číp O 2015 Repetition rate multiplication of a femtosecond frequency comb *Proc. SPIE* **9450** 94501L
- [17] Wilken T et al 2012 A spectrograph for exoplanet observations calibrated at the centimetre-per-second level *Nature* **485** 611–4
- [18] Jäger H, Musso M, Neureiter C and Windholz L 1990 Optical measurement of the free spectral range and spacing of plane and confocal Fabry–Perot interferometers *Opt. Eng.* **29** 42–6
- [19] Knight P D, Cruz-Cabrera A and Bergner B C 2002 High-resolution measurement of the free spectral range of an etalon *Proc. SPIE* **4772** 114–7
- [20] Williamson R and Terpstra C 2003 Precise free spectral range measurement of telecom etalon *Proc. SPIE* **5180** 274–82
- [21] Aketagawa M, Kimura S, Yashiki T, Iwata H, Banh T Q and Hirata K 2011 Measurement of a free spectral range of a Fabry–Perot cavity using frequency modulation and null method under off-resonance conditions *Meas. Sci. Technol.* **22** 025302
- [22] Ozdur I, Ozharar S, Quinlan F, Gee S and Delfyett P 2008 Modified Pound–Drever–Hall scheme for high-precision free spectral range measurement of Fabry–Perot etalon *Electron. Lett.* **44** 927–9
- [23] Mandridis D, Ozdur I, Bagnell M and Delfyett P 2010 Free spectral range measurement of a fiberized Fabry–Perot etalon with sub-Hz accuracy *Opt. Express* **18** 11264–9
- [24] Andrae T, König W, Wynands R, Leibfried D, Schmidt-Kaler F, Zimmermann C, Meschede D and Hänsch T W 1992 Absolute frequency measurement of the hydrogen 1S–2S transition and a new value of the Rydberg constant *Phys. Rev. Lett.* **69** 1923–6
- [25] Hagel G, Houssin M, Knoop M, Champenois C, Vedel M and Vedel F 2005 Long-term stabilization of the length of an optical reference cavity *Rev. Sci. Instrum.* **76** 123101
- [26] Black E D 2001 An introduction to Pound–Drever–Hall laser frequency stabilization *Am. J. Phys.* **69** 79–87
- [27] Yariv A 1989 *Quantum Electronics* (New York: Wiley) p 141
- [28] Hecht E 2002 *Optics* (New York: Addison-Wesley) p 416
- [29] Locke C R, Stuart D, Ivanov E N and Luiten A N 2009 A simple technique for accurate and complete characterisation of a Fabry–Perot cavity *Opt. Express* **17** 21935–43